

H35U Direct Vent Gas Stove

Model	H35U-NG	H35U-LP
Fuel Type	Natural Gas	Propane
Minimum Supply Pressure	5.0" W.C. (1.25 kPa)	11.0" W.C. (2.74 kPa)
Manifold Pressure - High	3.5" W.C. (0.87 kPa)	10" W.C. (2.49 kPa)
Manifold Pressure - Low	1.6" W.C. (0.40 kPa)	6.4" W.C. (1.59 kPa)
Orifice Size	#37 DMS	#52 DMS
Minimum Input	21,500 BTU/h (6.30 kW)	24,000 BTU/h (7.03 kW)
Maximum Input	30,000 BTU/h (8.78 kW)	29,500 BTU/h (8.64 kW)
Vent Sizing	4" Inner / 6-5/8" Outer	4" Inner / 6-5/8" Outer
Efficiency (Steady State)	75.27%	75.77%



Approved Venting Systems	
Flex Vent Systems:	FPI AstroCap™ Flex Vent
Rigid Pipe Vent Systems:	Simpson Direct Vent Pro® American Metal Products® Amerivent Direct Security Secure Vent® Selkirk Direct-Temp™ Metal-Fab® Sure Seal

Approved for sale in the U.S.A only. This appliance does not have a 7 day timer which is required for any appliance sold in Canada.

UNIT DIMENSIONS (TOP VENT)

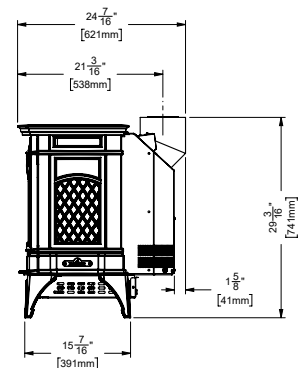
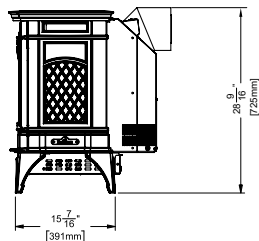
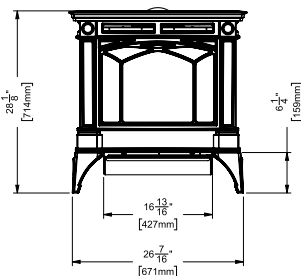
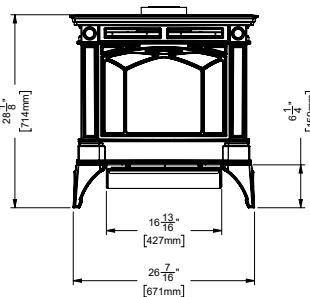
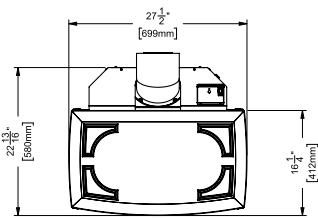
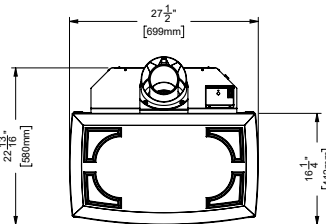

H35U Clearances

- A Side Wall to Unit 6-1/2" / 65 mm
- B Back Wall to Unit 6" / 152 mm
- C Vertical Vent Pipe to Back Wall 2" / 50 mm
- E Unit Corner to Wall 2" / 50 mm
- Unit Top to Alcove Ceiling 36" / 914 mm

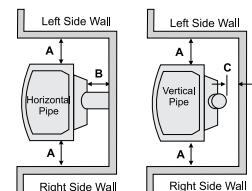

Minimum ceiling height is 36" / 914 mm from top of unit.

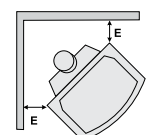

RIGID PIPE VENTING SYSTEMS HORIZONTAL OR VERTICAL TERMINATIONS

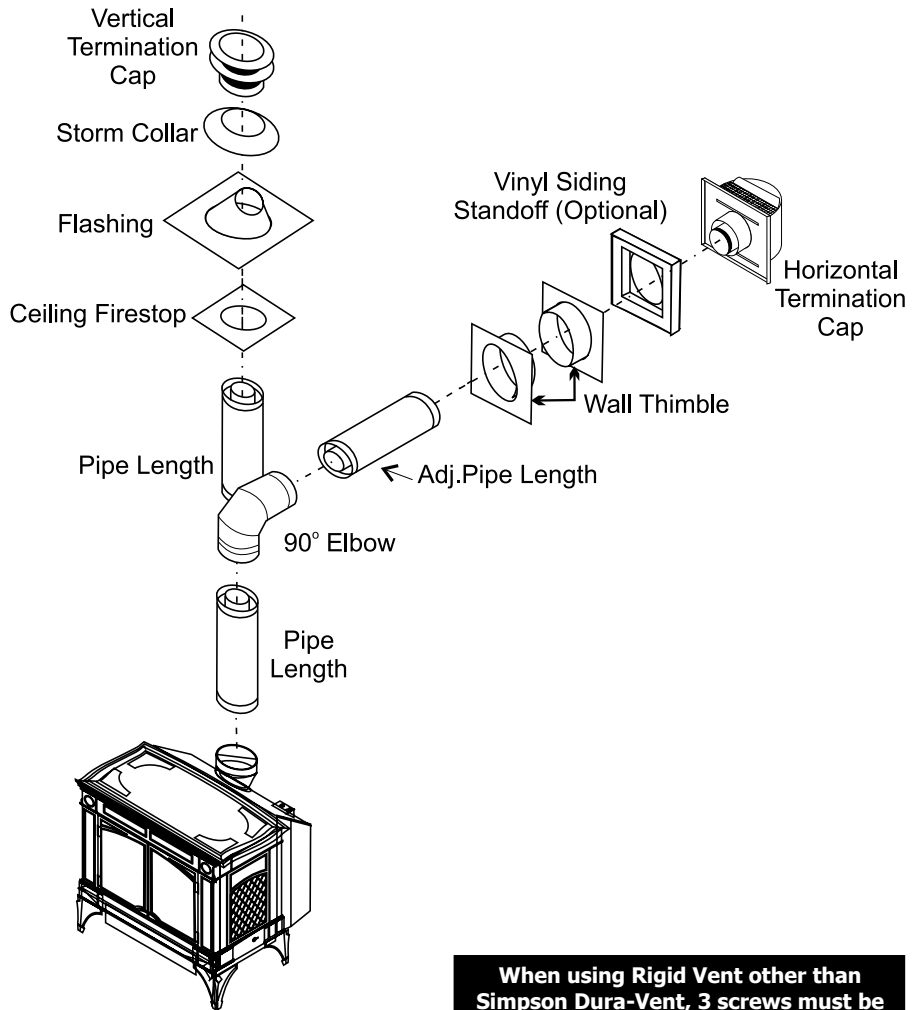
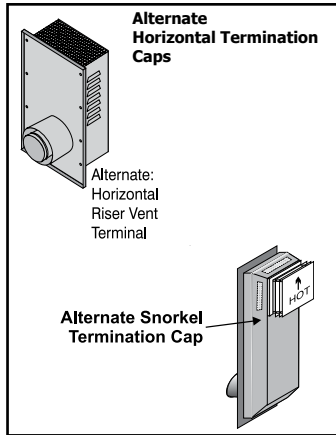

WARNING:

Do not combine venting components from different venting systems.

However use of the the AstroCap™ and FPI Riser is acceptable with all systems.

This product has been evaluated by Intertek for use with DuraVent Direct-Vent Pro, Selkirk Direct-Temp, Ameri Vent Direct venting and Security Secure Vent systems.

When using Rigid Vent other than Simpson Dura-Vent, 3 screws must be used to secure rigid pipe to adaptor.

The FPI AstroCap™ and FPI Riser Vent terminal are certified for installations using FPI venting systems as well as Simpson Dura-Vent® Direct Vent Pro, American Metal Products Ameri Vent Direct Vent, Security Secure Vent®, Selkirk Direct-Temp. AstroCap™ is a proprietary trademark of FPI Fireplace Products International Ltd. Dura-Vent® and Direct Vent Pro are registered and/or proprietary trademarks of Simpson Dura-Vent Co. Inc.

VENTING ARRANGEMENTS

Horizontal Terminations for All Venting Systems

The shaded areas in the diagram below show all allowable combinations of vertical runs with horizontal terminations. Maximum one 90° elbow (two 45° elbows equal one 90° elbow).

All approved caps listed in this manual - may be used.

Propane and Natural Gas: Residential, Manufactured and Mobile Homes Installations

The venting arrangements diagrammed below, have a min. of 75% (flue loss) efficiency with Fan Off, as required for manufactured homes. (Actual efficiency may be as high as 85%)

May be installed in Manufactured (Mobile) Homes after first sale.

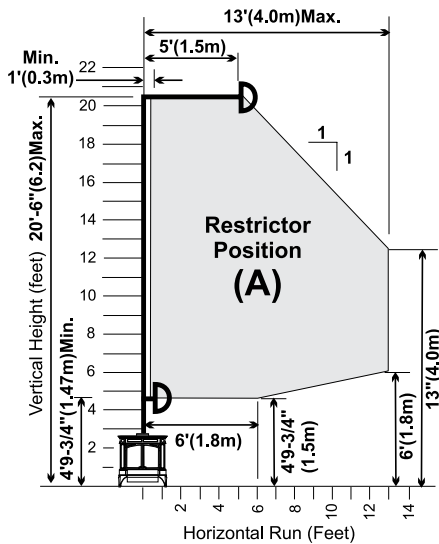

NOTE: See "Vent Restrictor Position" section for installation instructions for the Vent Restrictor Position.

Vertical Terminations Systems for Residential Manufactured and Mobile Homes

The shaded area in the diagram below shows all allowable combinations of straight vertical and offset to vertical runs with vertical terminations. Maximum two 45° elbows.

If the vent is ENCLOSED in a chase (min. size 9" x 9") maintain a 1-1/4" clearance to combustibles. *May be installed in Manufactured (Mobile) Homes after first sale.*

Offset to Vertical Terminations

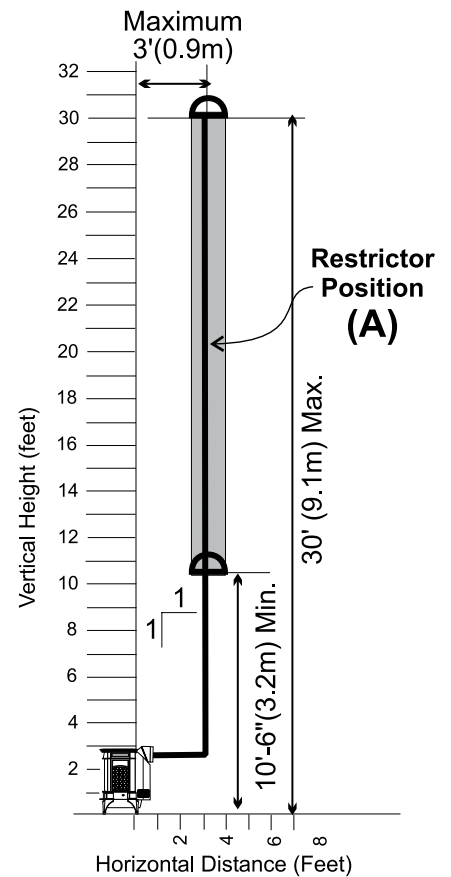
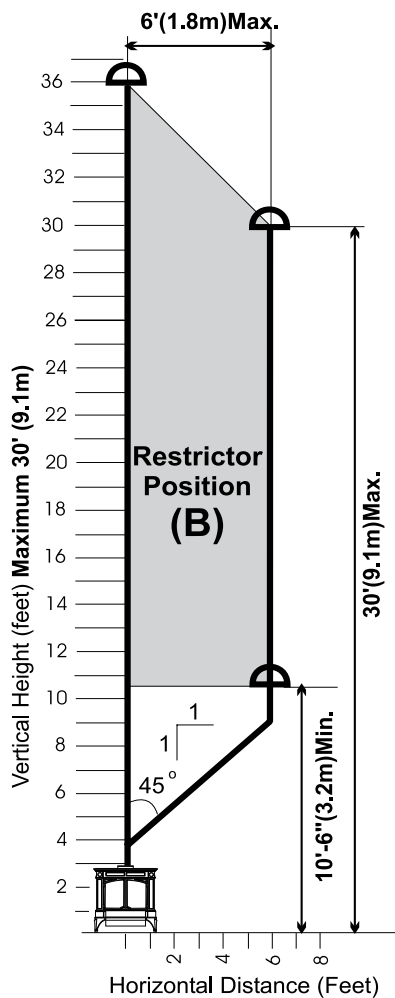

VENTING ARRANGEMENTS HORIZONTAL TERMINATIONS USING RIGID PIPE

The two diagrams show all allowable combinations of straight horizontal termination using Rigid Pipe. Restrictor position "A". Only a snorkel or FPI Riser vent may be used as shown. No other termination cap is permitted.

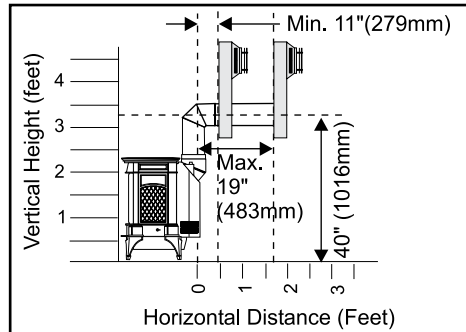

Snorkel Termination

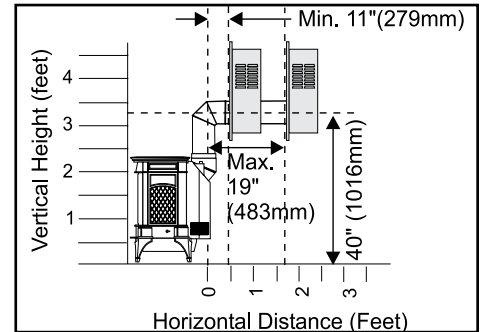

Riser Vent Termination

VENTING ARRANGEMENTS - STRAIGHT HORIZONTAL TERMINATION

The diagrams show all allowable combinations of straight horizontal termination using Rigid Pipe. Restrictor position "A".

Only a snorkel or FPI Riser vent may be used as shown in the noted diagrams. No other termination cap is permitted.

Dangerous operating conditions will occur if these instructions are not adhered to.

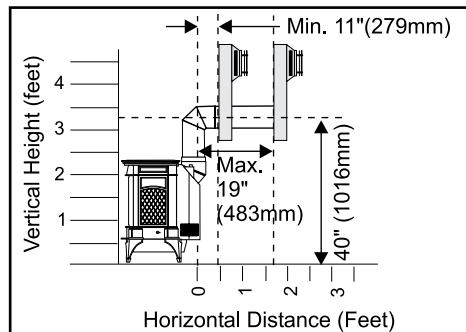

Snorkel Termination

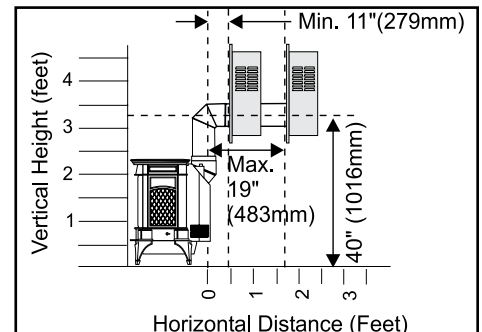

Riser Vent Termination

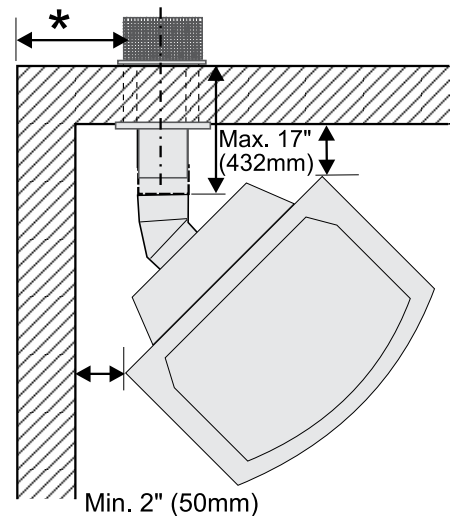

***If this is an outside corner, the minimum distance between the vent and the outside corner is 6" (15cm). See "F" on the diagram in the "Exterior Vent Terminal Locations" section.**

Horizontal Venting with Two (2) 90° Elbows

One 90° elbow = Two 45° elbows.

Option	V	H + H1	With these options, maximum total pipe length is 30 feet with minimum of 8 feet total vertical and maximum 8 feet total horizontal. Please note minimum 1 foot between 90° elbows is required.
A)	3' Min.	2' Min.	
B)	4' Min.	3' Min.	
C)	5' Min.	4' Min.	
D)	6' Min.	5' Min.	
F)	8' Min.	8' Min.	

Lengths do not include elbow indicated

Vent restrictor position A (fully open), refer to the "Vent Restrictor Position" section.

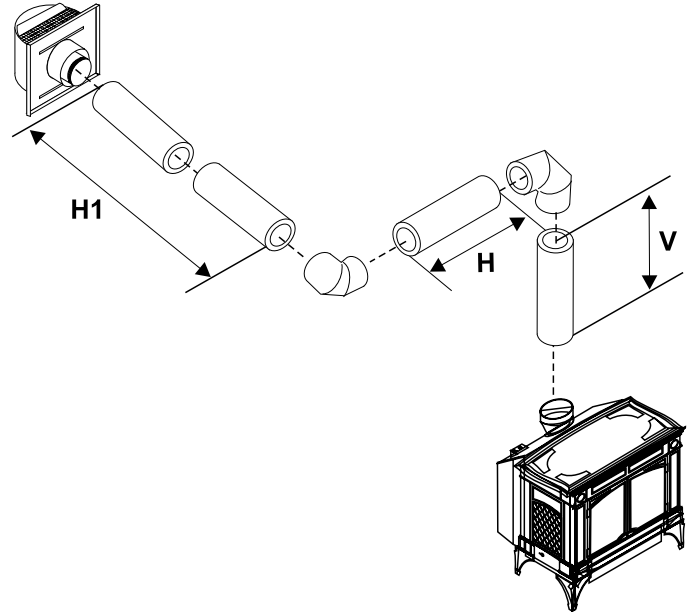

Horizontal Venting with Two (2) 90° Elbows

One 90° elbow = Two 45° elbows.

Option	H	V	H + H1	With these options, maximum total pipe length is 30 feet with minimum of 9 feet total vertical and maximum 8 feet total horizontal. Please note minimum 1 foot between 90° elbows is required.
A)	1' Max.	2' Min.	3' Max.	
B)	2' Max.	3' Min.	5' Max.	
C)	3' Max.	5' Min.	6' Max.	
D)	4' Max.	7' Min.	7' Max.	
E)	5' Max.	9' Min.	8' Max.	

Lengths do not include elbow indicated

Vent restrictor position A (fully open), refer to the "Vent Restrictor Position" section.

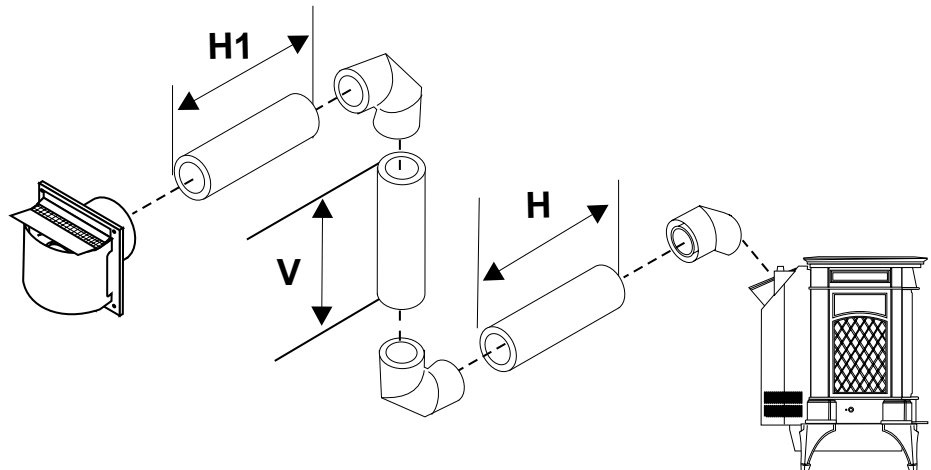

Vertical Venting with Two (2) 90° Elbows

One 90° elbow = Two 45° elbows.

Option	H	V	V + V1	With these options, maximum total pipe length is 30 feet with minimum of 6 feet total vertical and maximum 7 feet total horizontal. Please note minimum 1 foot between 90° elbows is required.
A)	1' Min.	3' Max.	2' Min.	
B)	2' Min.	4' Max.	3' Min.	
C)	3' Min.	5' Max.	4' Min.	
D)	4' Min.	6' Max.	5' Min.	
E)	5' Min.	7' Max.	6' Min.	
Lengths do not include elbow indicated				
Vent restrictor position A (fully open), refer to the "Vent Restrictor Position" section.				

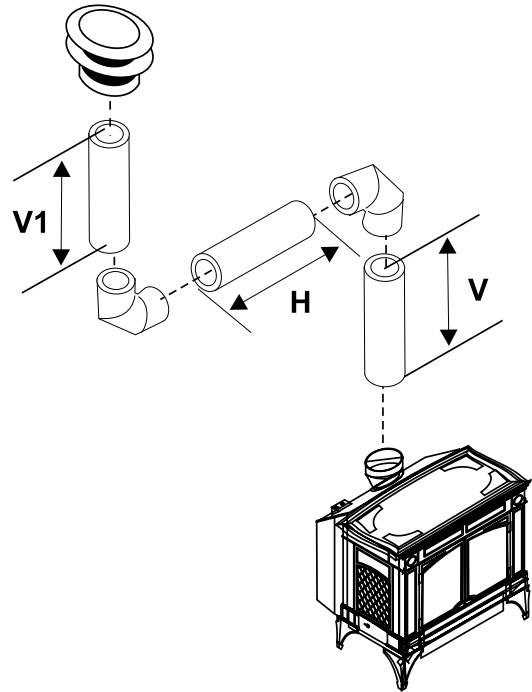

Vertical Venting with Two (2) 90° Elbows

One 90° elbow = Two 45° elbows.

Option	H + H1	V	With these options, maximum total pipe length is 30 feet with minimum of 6 feet total vertical and maximum 7 feet total horizontal. Please note minimum 1 foot between 90° elbows is required.
A)	2' Max.	2' Min.	
B)	3' Max.	3' Min.	
C)	4' Max.	4' Min.	
D)	5' Max.	5' Min.	
E)	6' Max.	6' Min.	
Lengths do not include elbow indicated			
Vent restrictor position A (fully open), refer to the "Vent Restrictor Position" section.			

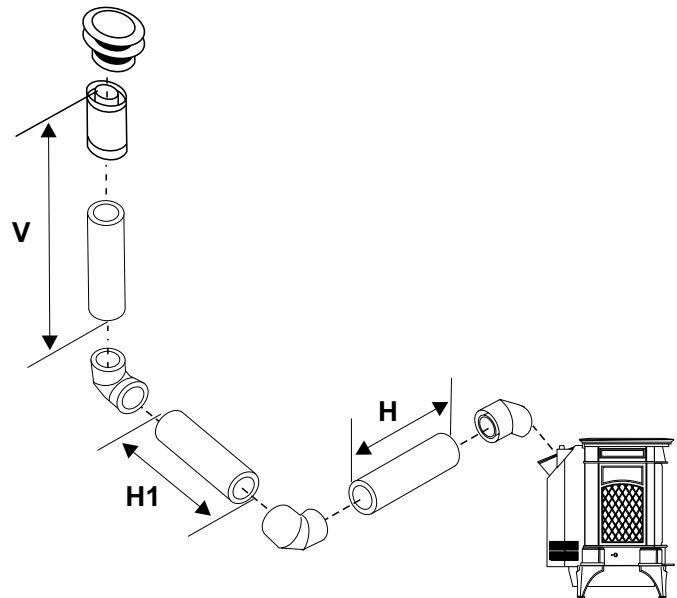

VERTICAL TERMINATION WITH CO-LINEAR FLEX SYSTEM

THE APPLIANCE MUST NOT BE CONNECTED TO A CHIMNEY FLUE SERVING A SEPARATE SOLID FUEL BURNING APPLIANCE.

This appliance is designed to be attached to two 3" (76 mm) co-linear aluminum flex running the full length of the chimney. See the Venting Arrangements chart below for minimum and maximum flue lengths. See chart below for minimum distances from roof. Periodically check that the vent is unrestricted.

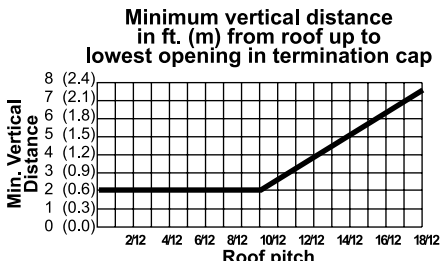

Venting Arrangements - Vertical Terminations with Co-linear Flex System for both Residential & Manufactured Homes into Masonry Fireplaces

The shaded area in the diagram shows the allowable vertical terminations. **Note: Must remove 4 screws from stove collar and rotate 180° to have collar facing straight back. Secure into place with 4 screws.**

Straight Vertical Terminations

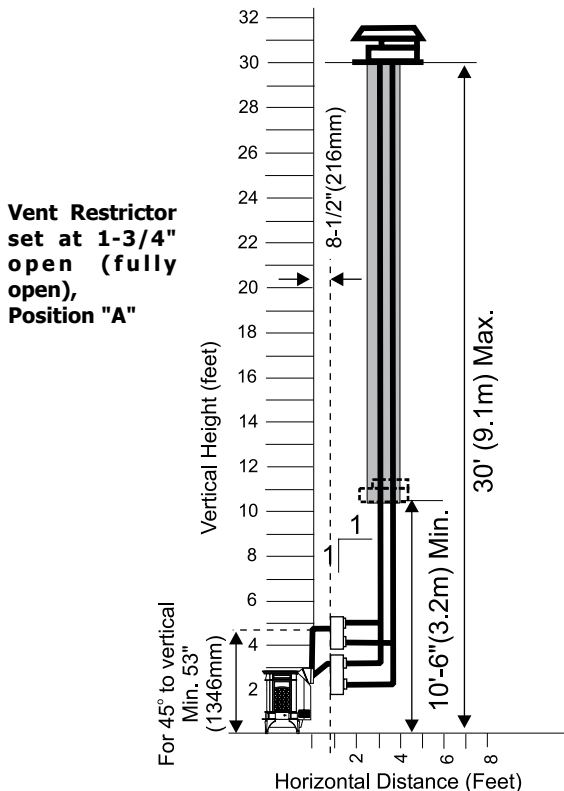

Masonry chimneys may take various contours which the flexible liner will accommodate. However, **keep the flexible liner as straight as possible**, avoid unnecessary bending.

The Air Intake pipe must be attached to the inlet air collar of the termination cap.

Required Parts:

Part #	Description
946-529	Co-linear DV Vertical Termination Cap
948-305	3" Flex - 35 ft.
946-563	Co-Axial to Co-Linear Adaptor Kit which contains the following: Co-linear Flex Adaptor Outer Pipe Inner Pipe Adaptor

Alternate Approved Caps:

Part #	Description
46DVA-GK	3" Co-linear Adaptor with flashing
446DVA-VC	Vertical Termination Cap Or
46DVA-VCH	High Wind Cap

NOTE

In areas of consistently high winds, we recommend using the Simpson Dura-Vent System (46DVA-GKadapter and 46DVA-VCH high-wind cap).
The Air Intake pipe must be attached to the inlet air collar of the termination cap.

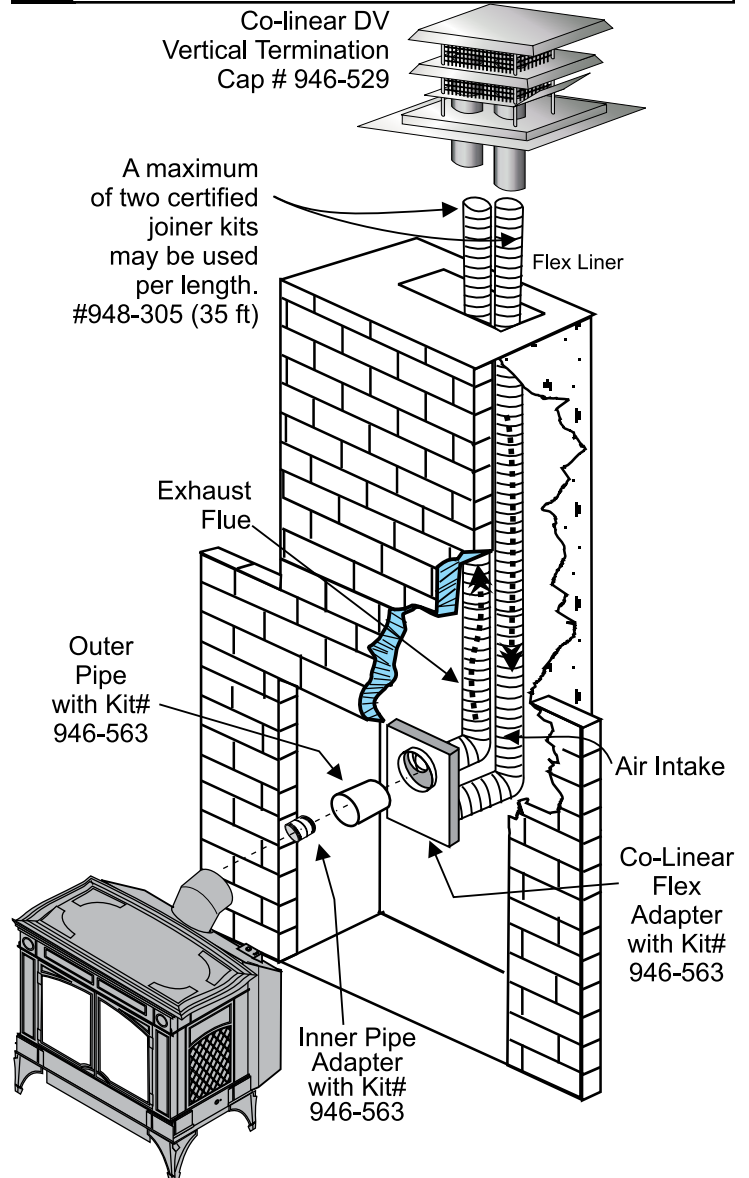

DV STOVE HORIZONTAL TERMINATION VENT KIT

DV 2 ft. Stove Vent Kit (Part # 946-116) and DV 4 ft. Stove Vent Kit (Part #946-216) includes all the parts needed to install the H35 Direct Vent unit with minimum horizontal and vertical vent dimensions. For installations that require longer vertical and/or horizontal vents use the Dura-Vent system as shown in the "Dura-Vent Termination Kit" and "Dura-Vent Venting Components" sections.

Qty.	Description
1)	1 Rigid Pipe Section (Kit # 946-116: 2 ft. (1.2m) length, Kit # 946-216: 4 ft. (1.2m) length), 6-1/2" (165mm) inside diameter
2)	1 Flex Liner, compressed aluminum 2 ply liner, 4" (102mm) inside diameter
3)	4 Spring Spacers
4)	1 90 deg. Elbow
5)	1 Adjustable pipe section 13-1/2" to 24" (343mm x 610mm), 2 pcs.
6)	1 Thimble Cover
7)	1 Wall Thimble (2 pcs.)
8)	1 Adaptor
9)	1 AstroCap Termination Cap
10)	2 Trim Collars
11)	1 Tube of Mill-Pac, high temperature sealant
12)	12 Screws, #8 x 1/2" Self tapping, Stainless Steel
13)	14 Screws, #8 x 1/2" Self tapping, Black
14)	4 Screws #8 x 1-1/2" Drill Point, Black
15)	4 Screws #8 x 1-1/2" Drill Point, Stainless Steel
16)	8 Wood screws #8 x 1"

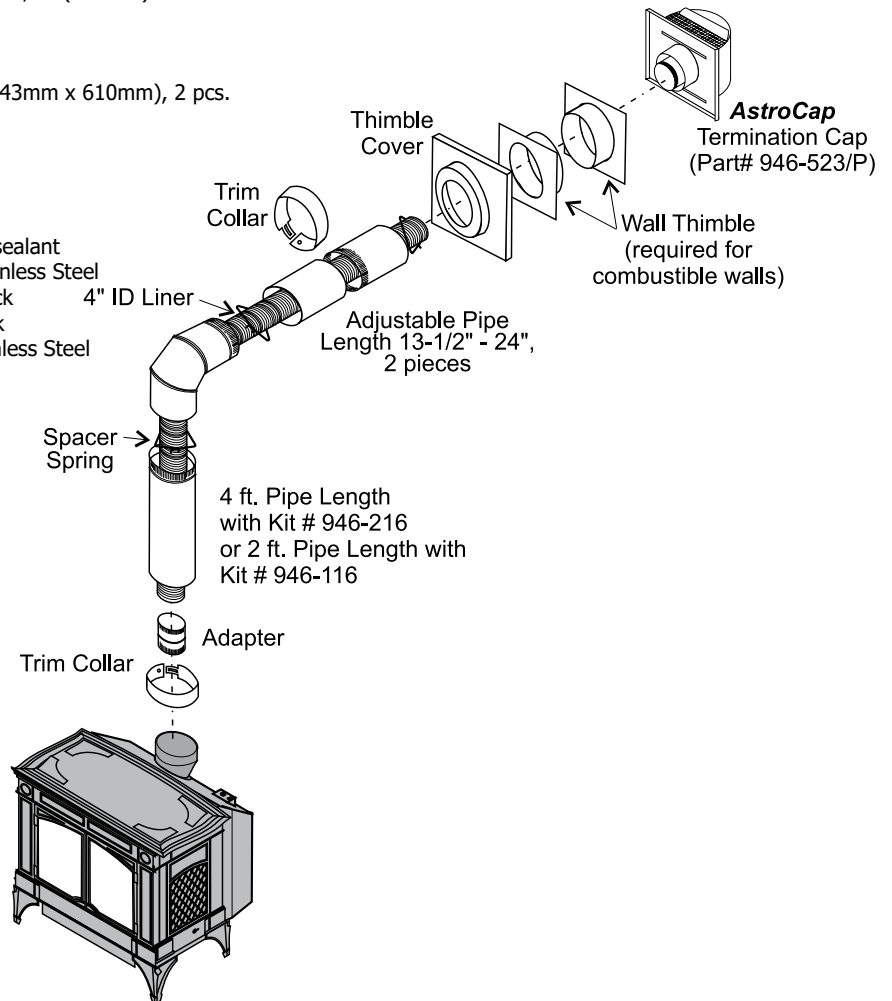

Note:

a) Liner sections should be continuous without any joints or seams.

b) This is an approved system, therefore components in this system must not be substituted for any other manufacturer's products.

DURA-VENT TERMINATION KIT

Planning Your Dura-Vent Installation

There are two basic types of Dura-Vent Direct Vent System installations: horizontal termination and vertical termination. Confirm the maximum horizontal run and maximum vertical rise from the diagrams in the "Venting Arrangement" section.

When planning your installation, it will be necessary to select the proper length of vent pipe for your particular requirements. For horizontal installations, determine the minimum clearance from the rear of the unit to the wall. It is also important to note the wall thickness. (The wall thimble is suitable for 2 x 4 or 2 x 6 wall construction.) Select the amount of vertical rise desired for "vertical-to-horizontal" type installations.

Warning: Always maintain required clearances (air spaces) to nearby combustibles to prevent a fire hazard. Do not fill air spaces with insulation.

The minimum clearance requirements between the outer wall of the vent pipe and nearby combustible surfaces is 1-1/4 inch. Be sure to check the vent termination clearance requirements from decks, windows, soffits, gas regulators, air supply inlets and public walkways as specified in the "Exterior Vent Terminal Locations" section and in your local building codes.

To determine the length of vent pipe required for vertical installations, measure the distance from the unit flue outlet to the ceiling, the ceiling thickness, the vertical rise in an attic or second storey, and allow for sufficient vertical height above the roof line.

For multi-storey applications, fire stops are required at each floor level. If an offset is needed, additional pipe, elbows and supports will be required.

Do not exceed the maximum number of elbows. One 90° for horizontal terminations and two 45° for vertical termination.

