

H27U Direct Vent Gas Stove

Model	H27U-NG	H27U-LP
Fuel Type	Natural Gas	Propane
Minimum Supply Pressure	5" W.C. (1.25 kPa)	11" W.C. (2.74 kPa)
Manifold Pressure - High	3.5" W.C. (0.87 kPa)	10" W.C. (2.49 kPa)
Manifold Pressure - Low	1.6" W.C. (0.40 kPa)	6.4" W.C. (1.59 kPa)
Orifice Size	#42 DMS	#54 DMS
Minimum Input	18,000 BTU/h (5.28 kW)	17,500 BTU/h (5.13 kW)
Maximum Input	25,000 BTU/h (7.32 kW)	22,000 BTU/h (6.45 kW)
Vent Sizing (Rear Vent)	4" Inner / 6-5/8" Outer	4" Inner / 6-5/8" Outer
Vent Sizing (Top Vent)	4" Inner / 6-5/8" Outer	4" Inner / 6-5/8" Outer
Efficiency (Steady State)	67.63%	66.51%



CLEARANCES TO COMBUSTIBLES

The clearances listed are MINIMUM distances. Measure the clearance to both the appliance and the chimney connector. **The farthest distance is correct if the two clearances do not coincide.**

For example, if the appliance is set as indicated in one of the figures but the connector is too close, move the stove until the correct clearance to the connector is obtained.

This appliance may be installed only with the clearances as shown in the situations pictured. **Do not combine clearances from one type of installation with another in order to achieve closer clearances.**

This unit can be installed on a solid combustible surface like a wood floor. This unit can also be installed directly on carpeting or vinyl.

Use the minimum clearances shown in the diagrams below:

H27U-NG & H27U-LP Clearances

- A Left Side Wall to Unit* 6" / 150 mm
- B Back Wall to Unit 3" / 75 mm
- C Vertical Vent Pipe to Back Wall 2" / 50 mm
- E Unit Corner to Wall 2" / 50 mm
- Unit Top to Alcove Ceiling 24" / 610 mm

Minimum ceiling height is 24" / 610 mm from top of unit.

Approved for sale in the U.S.A only. This appliance does not have a 7 day timer which is required for any appliance sold in Canada.

Approved Venting Systems	
Flex Vent Systems:	FPI AstroCap™ Flex Vent
Rigid Pipe Vent Systems:	Simpson Direct Vent Pro® Selkirk Direct-Temp™ Metal-Fab® Sure Seal American Metal Products® Amerivent Direct Security Secure-Vent™ ICC Excel Direct

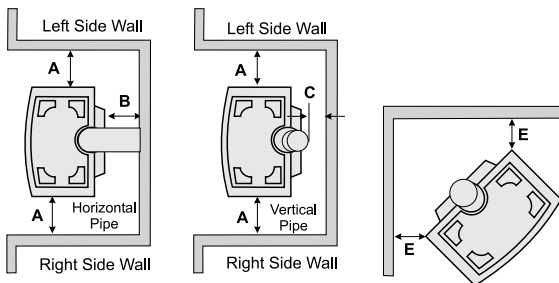

UNIT DIMENSIONS WITH VERTICAL VENTING

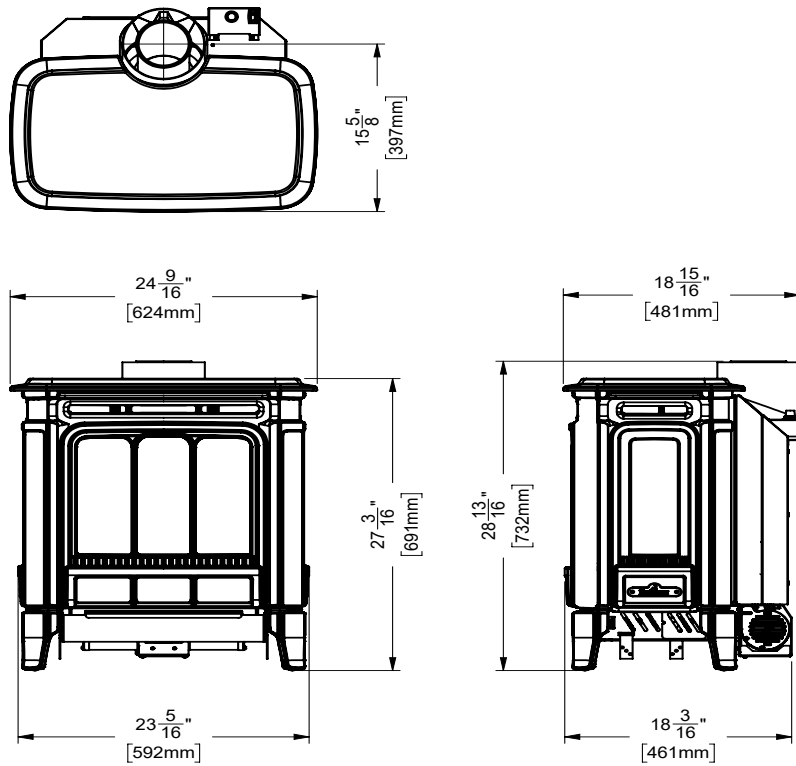

UNIT DIMENSIONS WITH HORIZONTAL VENTING

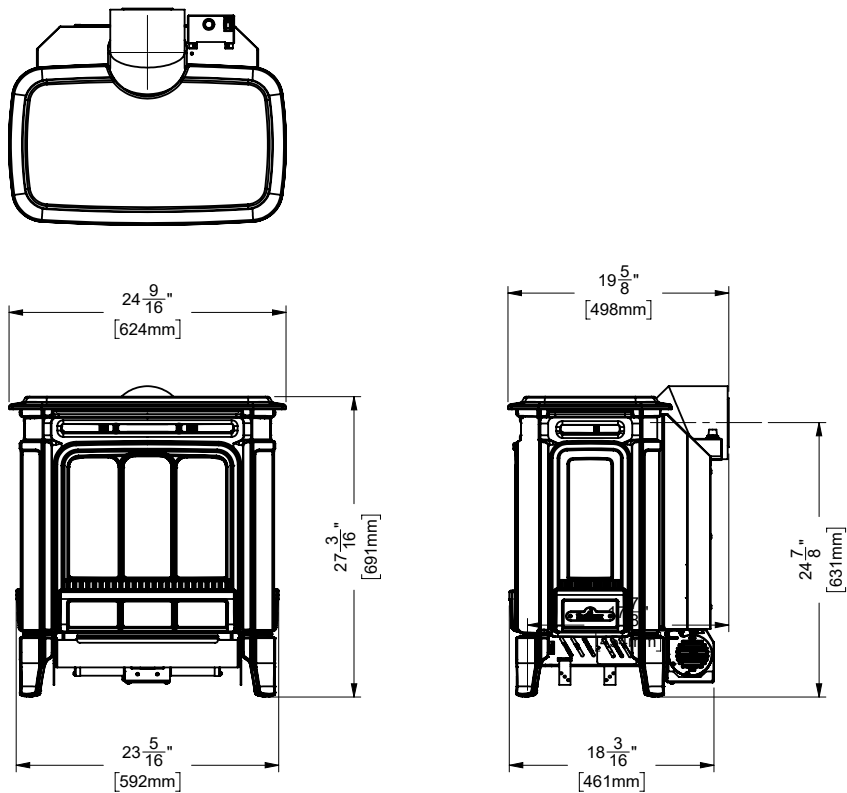

RIGID PIPE VENTING SYSTEMS

Horizontal or Vertical Terminations

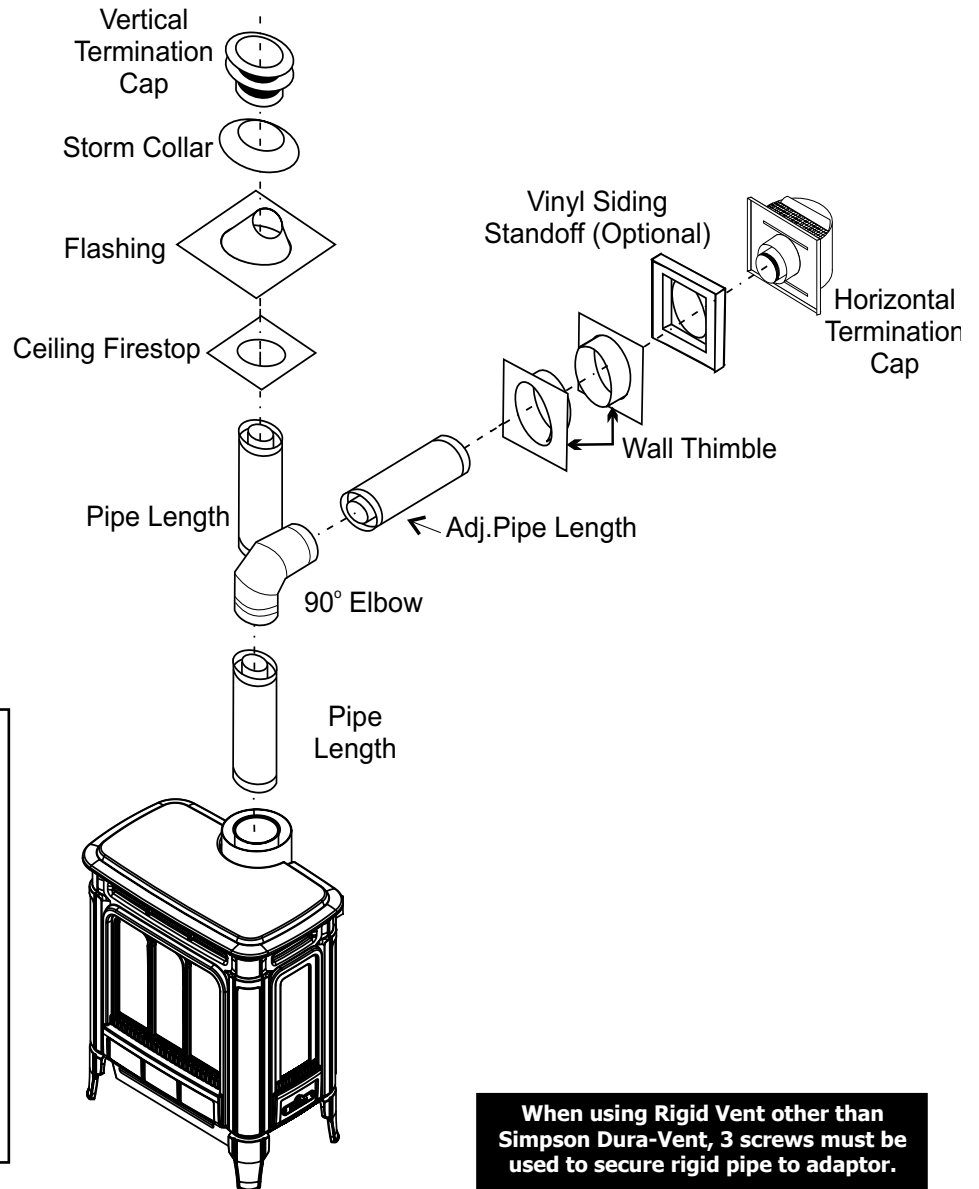
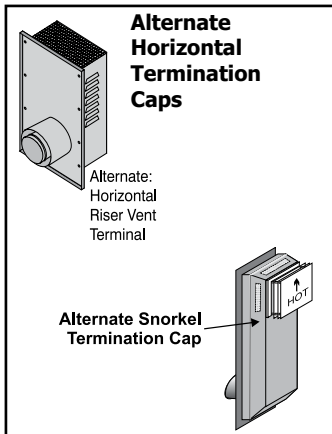

WARNING:

Do not combine venting components from different venting systems.

However use of the the AstroCap™ and FPI Riser is acceptable with all systems.

This product has been evaluated by Intertek for using a Rigid Pipe Adaptor in conjunction with Duravent Direct-Vent Pro, Selkirk Direct-Temp, Ameri Vent Direct, ICC Excel venting and Security Secure Vent systems. Use of these systems with the Rigid Pipe adaptor is deemed acceptable and does not affect the Intertek WHI listing of components.

When using Rigid Vent other than Simpson Dura-Vent, 3 screws must be used to secure rigid pipe to adaptor.

The FPI AstroCap™ and FPI Riser Vent terminal are certified for installations using FPI venting systems as well as Simpson Dura-Vent® Direct Vent, American Metal Products Ameri Vent Direct Vent, Security Secure Vent®, Selkirk Direct-Temp and ICC Excel. AstroCap™ is a proprietary trademark of FPI Fireplace Products International Ltd. Dura-Vent® and Direct Vent Pro are registered and/or proprietary trademarks of Simpson Dura-Vent Co. Inc.

VENTING ARRANGEMENTS

Horizontal Terminations for All Venting Systems

The shaded areas in the diagram below show all allowable combinations of vertical runs with horizontal terminations. Maximum one 90° elbow (two 45° elbows equal one 90° elbow).

Propane and Natural Gas: Residential, Manufactured and Mobile Homes Installations

May be installed in Manufactured (Mobile) Homes after first sale.

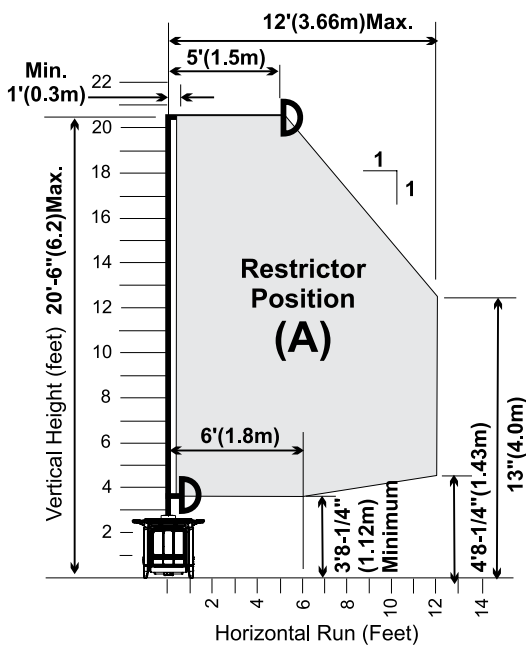

Vertical Terminations Systems for Residential Manufactured and Mobile Homes

The shaded area in the diagram below shows all allowable combinations of straight vertical and offset to vertical runs with vertical terminations. Maximum two 45° elbows.

If the vent is ENCLOSED in a chase (min. size 9" x 9") maintain a 1-1/4" clearance to combustibles.

May be installed in Manufactured (Mobile) Homes after first sale.

Offset to Vertical Terminations

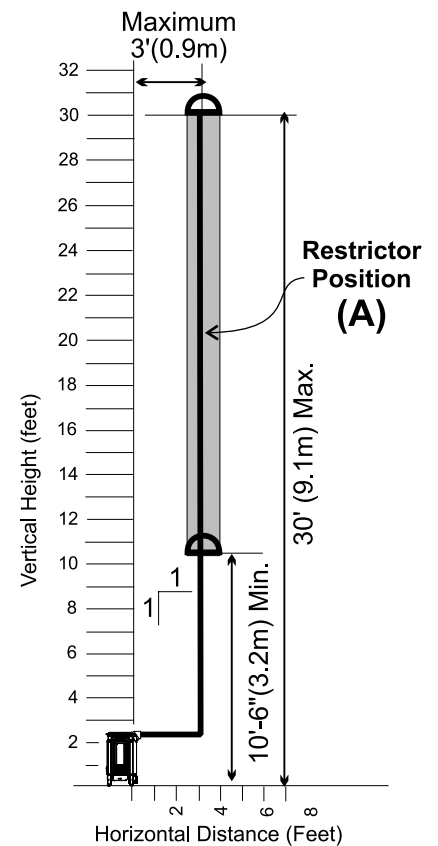
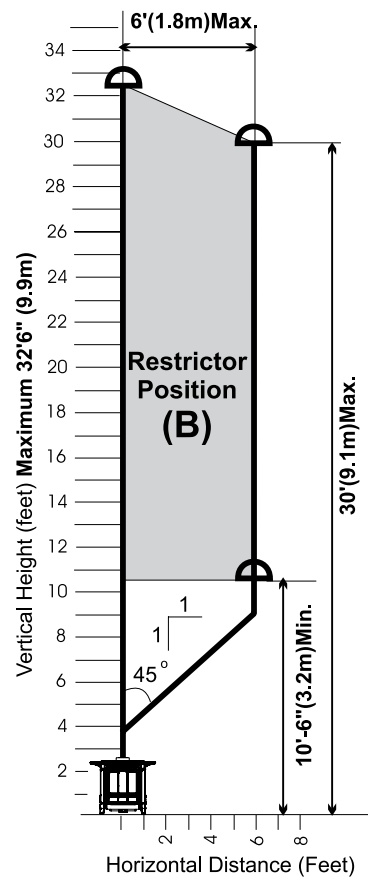

Venting Arrangements - Horizontal Terminations using Dura-Vent Venting System and/or Riser Vent Termination

The two diagrams show all allowable combinations of straight horizontal termination with one 45° elbow off the unit with Snorkels or FPI Riser Vent. Restrictor position "A".

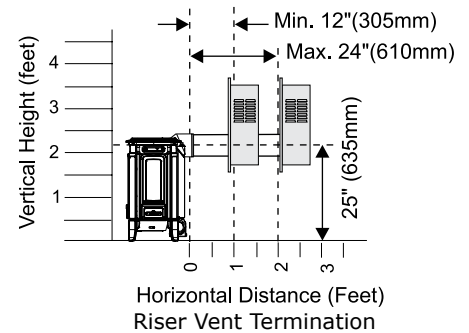
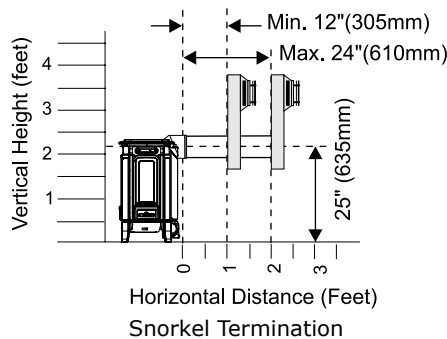

Horizontal Venting with Two (2) 90° Elbows

<i>One 90° elbow = Two 45° elbow</i>			
Option	V	H + H1	With these options, maximum total pipe length is 30 feet with minimum of 6 feet total vertical and maximum 8 feet total horizontal. Please note minimum 1 foot between 90° elbows is required.
A)	2' Min.	4' Max.	
B)	3' Min.	5' Max.	
C)	4' Min.	6' Max.	
D)	5' Min.	7' Max.	
E)	6' Min.	8' Max.	
Lengths do not include elbow indicated.			
Vent restrictor position A (fully open), refer to the "Vent Restrictor Position" section.			

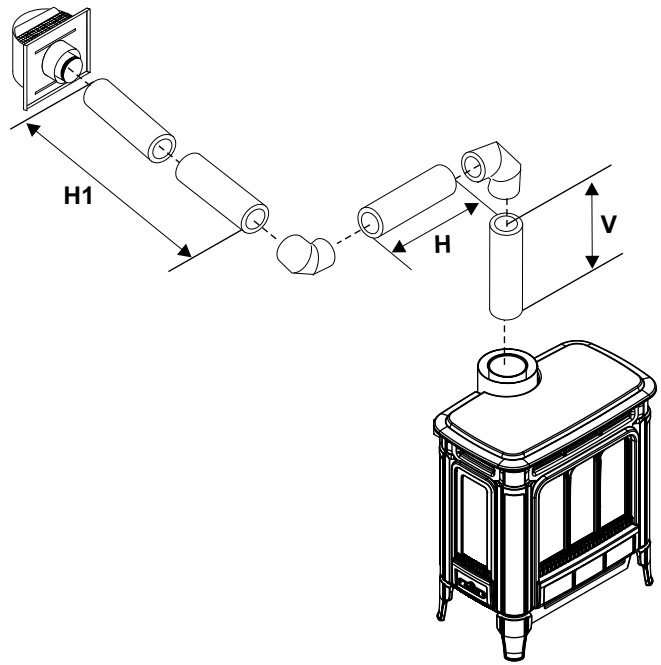

Horizontal Venting with Two (2) 90° Elbows

<i>One 90° elbow = Two 45° elbow</i>				
Option	H	V	H + H1	With these options, maximum total pipe length is 30 feet with minimum of 8 feet total vertical and maximum 8 feet total horizontal. Please note minimum 1 foot between 90° elbows is required.
A)	1' Max.	1' Min.	3' Max.	
B)	2' Max.	2' Min.	5' Max.	
C)	3' Max.	4' Min.	6' Max.	
D)	4' Max.	6' Min.	7' Max.	
E)	5' Max.	8' Min.	8' Max.	
Lengths do not include elbow indicated.				
Vent restrictor position A (fully open), refer to the "Vent Restrictor Position" section.				

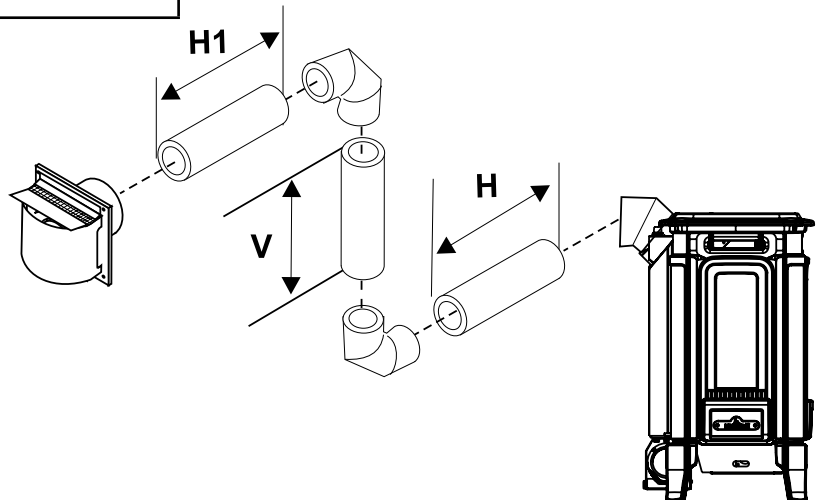

Vertical Venting with Two (2) 90° Elbows

One 90° elbow = Two 45° elbows.

Option	V	H	V + V1	With these options, max. total pipe length is 30 feet with min. of 6 feet total vertical and max. 8 feet total horizontal. Please note min. 1 foot between 90° elbows is required.
A)	1' Min.	4' Max.	2' Min.	
B)	2' Min.	5' Max.	3' Min.	
C)	3' Min.	6' Max.	4' Min.	
D)	4' Min.	7' Max.	5' Min.	
E)	5' Min.	8' Max.	6' Min.	

Lengths do not include elbow indicated

Vent restrictor position A (fully open), refer to the "Vent Restrictor Position" section.

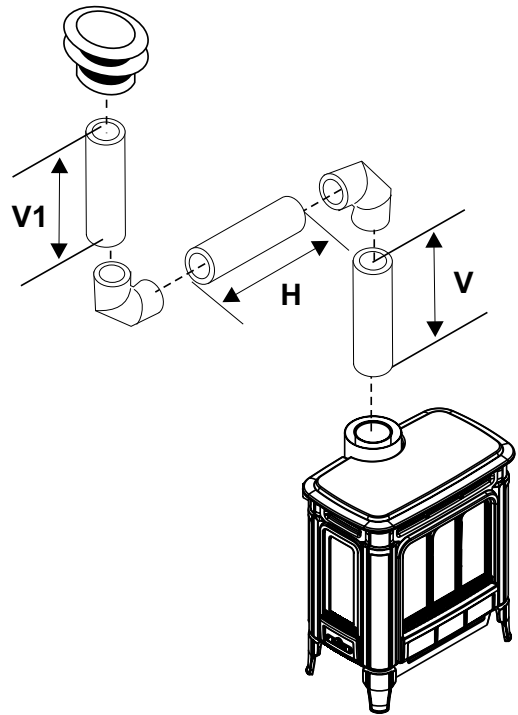

Vertical Venting with Two (2) 90° Elbows

One 90° elbow = Two 45° elbows.

Option	H + H1	V	With these options, max. total pipe length is 30 feet with min. of 6 feet total vertical and max. 6 feet total horizontal. Please note min. 1 foot between 90° elbows is required.
A)	2' Max.	2' Min.	
B)	3' Max.	3' Min.	
C)	4' Max.	4' Min.	
D)	5' Max.	5' Min.	
E)	6' Max.	6' Min.	

Lengths do not include elbow indicated

Vent restrictor position A (fully open), refer to the "Vent Restrictor Position" section.

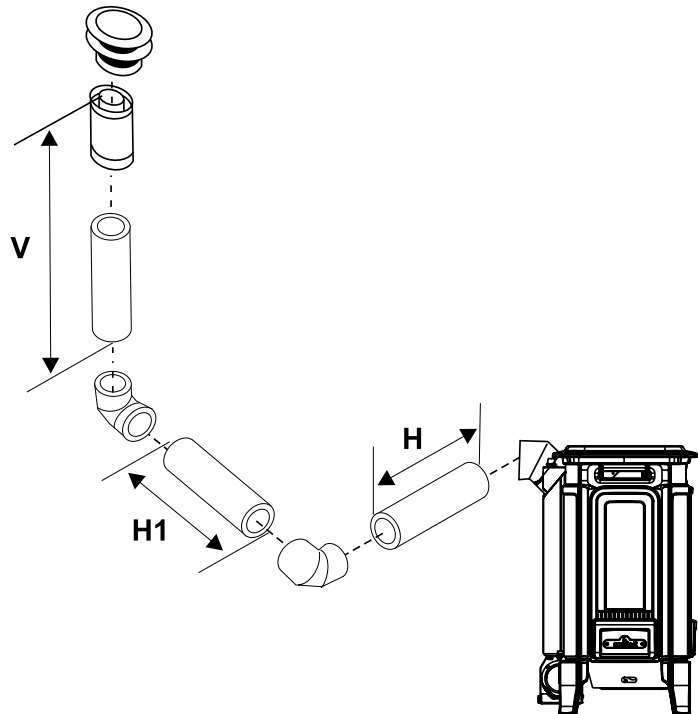

VERTICAL TERMINATION WITH CO-LINEAR FLEX SYSTEM

THE APPLIANCE MUST NOT BE CONNECTED TO A CHIMNEY FLUE SERVING A SEPARATE SOLID FUEL BURNING APPLIANCE.

Masonry chimneys may take various contours which the flexible liner will accommodate. However, **keep the flexible liner as straight as possible**, avoid unnecessary bending.

The Air Intake pipe must be attached to the inlet air collar of the termination cap.

This appliance is designed to be attached to two 3" (76mm) co-linear aluminium flex running the full length of the chimney. See the Venting Arrangements chart below for minimum and maximum flue lengths. See chart below for minimum distances from roof. Periodically check that the vent is unrestricted.

Required Parts:

Part #	Description
946-529	Co-linear DV Vertical Termination Cap
948-305	3" Flex - 35 ft.
946-563	Co-Axial to Co-Linear Adapter Kit which contains the following: Co-linear Flex Adapter Outer Pipe Inner Pipe Adapter

Alternate Approved Caps

Part #	Description
46DVA-HC	Vertical Termination Cap
OR	
46DVA-VCH	High Wind Cap
46DVA-GK	3" Co-linear Adapter with flashing

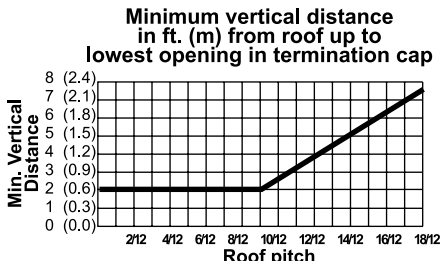

Venting Arrangements - Vertical Terminations with Co-linear Flex System for both Residential & Manufactured Homes into Masonry Fireplaces

The shaded area in the diagram shows the allowable vertical terminations. **Note: Must remove 4 screws from stove collar and rotate 180° to have collar facing straight back. Secure into place with 4 screws.**

Straight Vertical Terminations

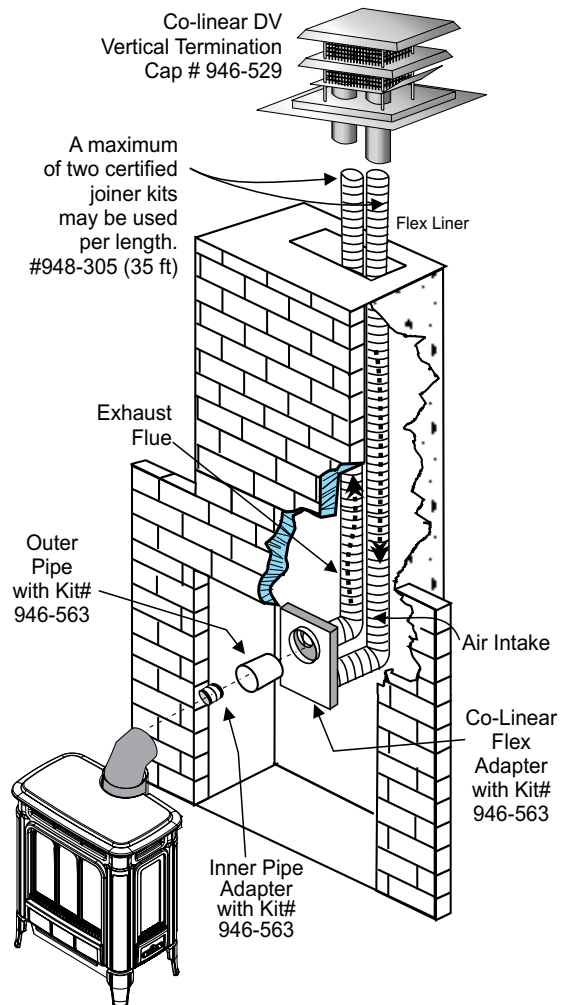
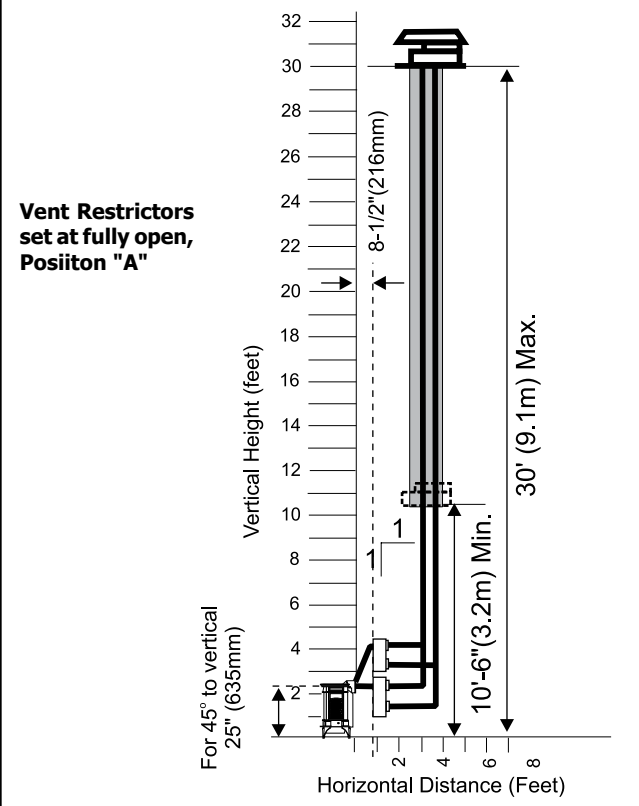

DV STOVE HORIZONTAL VENT KIT

DV 2 ft. Stove Vent Kit (Part # 946-116) and DV 4 ft. Stove Vent Kit (946-216) includes all the parts needed to install the H27 Direct Vent unit with minimum horizontal and vertical vent dimensions. For installations that require longer vertical and/or horizontal vents use the Dura-Vent system as shown in the "Dura-Vent Termination Kit" and "Dura-Vent Venting Components" sections.

Qty.	Description
1) 1	Rigid Pipe Section (Kit # 946-116: 2 ft. (1.2m) length, Kit # 946-216: 4 ft. (1.2m) length, 6-1/2" (165mm) inside diameter
2) 1	Flex Liner, compressed aluminium 2 ply liner, 4" (102mm) inside diameter
3) 4	spring spacers
4) 1	90 deg. Elbow
5) 1	Adjustable pipe section 13-1/2" to 24" (343mm x 610mm), 2 pcs.
6) 1	Thimble Cover
7) 1	Wall Thimble (2 pcs.)
8) 1	Adapter
9) 1	AstroCap Termination Cap
10) 2	Trim Collars
11) 1	Tube of Mill-Pac, high temperature sealant
12) 12	Screws, #8 x 1/2" Self tapping, Stainless Steel
13) 14	Screws, #8 x 1/2" Self tapping, Black
14) 4	Screws #8 x 1-1/2" Drill Point, Black
15) 4	Screws #8 x 1-1/2" Drill Point, Stainless Steel
16) 8	Wood screws #8 x 1"

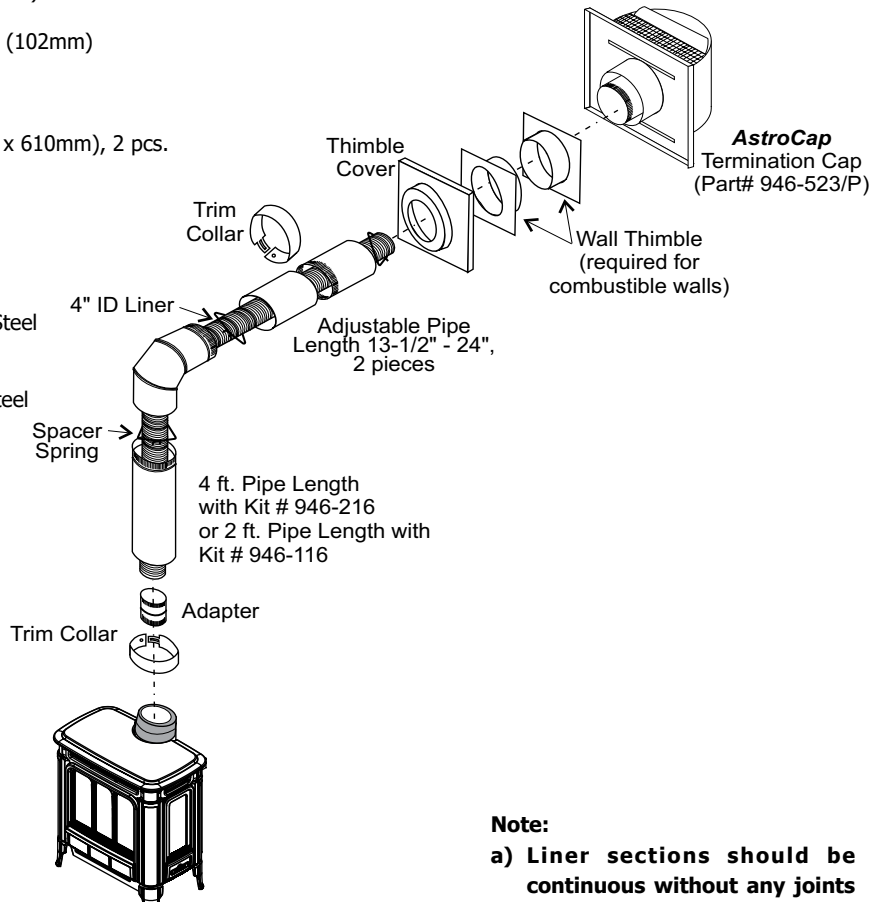

Note:

- a) Liner sections should be continuous without any joints or seams.
- b) This is an approved system, therefore components in this system must not be substituted for any other manufacturer's products.

RESIDENTIAL AND MANUFACTURED HOMES / MOBILE HOMES

Minimum Horizontal Termination Installations Planning Your Venting Installation

See the "Exterior Vent Terminal Locations" section for requirements. The gas stove is approved for a minimum horizontal termination with the FPI Riser Vent Kit. See the diagram for minimum and maximum pipe lengths.

When planning your installation, it will be necessary to select the proper length of vent pipe for your particular requirements. Determine the minimum clearance to combustibles from the rear of the unit to the wall. It is also important to note the wall thickness. Before cutting the vent hole through the wall ensure that ALL vent and termination clearances (see the "Exterior Vent Terminal locations" section) will be met.

*If this is an outside corner, the minimum distance between the vent and the outside corner is 6" (15cm). See "F" on the diagram in the "Exterior Vent Terminal Locations" section.

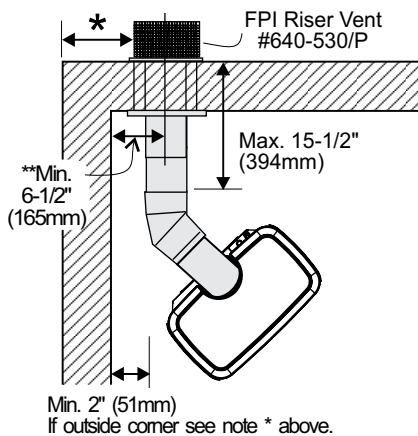

Min. 2" (51mm)
If outside corner see note * above.

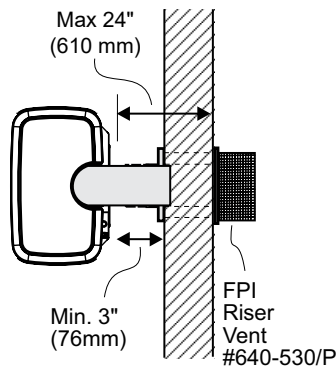

NOTE: Ensure compliance with the outside vent terminal location before cutting hole as both dimensions must be met.

You will require the following components with your new Hampton® Rear Vent Direct Vent Freestanding Gas Stove. Please review your product to make sure you have everything you need. In the event that you are missing any part, contact your dealer. Decorative brass or chrome trim kits are available from Simpson Dura-Vent for their wall thimbles, as well as a square wall thimble cover.

Note: These are the minimum pieces required. Other parts may be required for your particular installation.

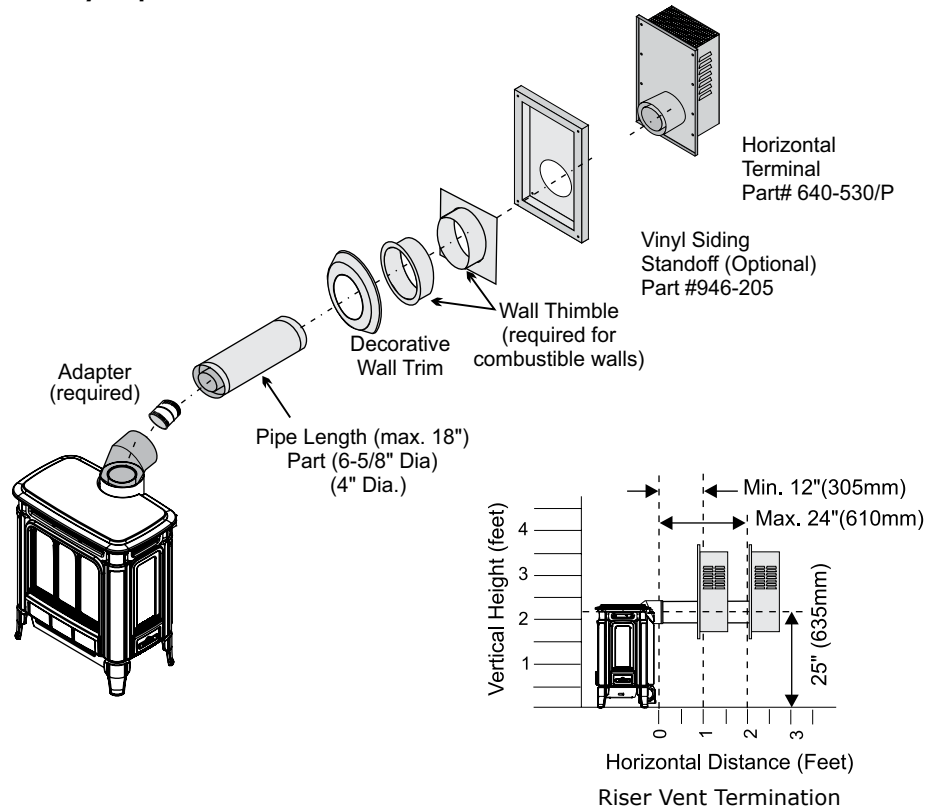

Minimum components for a Horizontal Installation:

- | | |
|---------|---|
| 946-544 | Horizontal Termination Kit which includes: |
| 1 | 6-5/8" Dia. x 18" Black Pipe |
| 1 | 4" Dia. x 18" Aluminum Vent |
| 1 | Wall Penetration Heat Shield (Wall Thimble) (2 pcs) |
| 1 | 640-530/P Riser Vent Terminal |
| 1 | Decorative Wall Trim (Black) |
| 1 | 948-128 Tube Mill-Pac Screws |

Optional Components:

- | | |
|-----------|--|
| 946-204 | 45° Elbow - 6-5/8" Black pipe and 4" Aluminum Vent |
| 946-205 | Vinyl Siding Shield for Riser Vent Terminal |
| 946-208/P | Vent Guard |

DURA-VENT TERMINATION KIT

Planning Your Dura-Vent Installation

There are two basic types of Dura-Vent Direct Vent System installations: horizontal termination and vertical termination. Confirm the maximum horizontal run and maximum vertical rise from the diagrams in the "Venting Arrangement" section.

When planning your installation, it will be necessary to select the proper length of vent pipe for your particular requirements. For horizontal installations, determine the minimum clearance from the rear of the unit to the wall. It is also important to note the wall thickness. (The wall thimble is suitable for 2 x 4 or 2 x 6 wall construction.) Select the amount of vertical rise desired for "vertical-to-horizontal" type installations.

Warning: Always maintain required clearances (air spaces) to nearby combustibles to prevent a fire hazard. Do not fill air spaces with insulation.

The minimum clearance requirements between the outer wall of the vent pipe and nearby combustible surfaces is 1-1/2", except when passing through a wall, ceiling, or at the termination where the use of a firestop or wall thimble reduces the required clearance to 1". Be sure to check the vent termination clearance requirements from decks, windows, soffits, gas regulators, air supply inlets and

public walkways as specified in the "Exterior Vent Terminal Locations" section and in your local building codes.

To determine the length of vent pipe required for vertical installations, measure the distance from the unit flue outlet to the ceiling, the ceiling thickness, the vertical rise in an attic or second storey, and allow for sufficient vertical height above the roof line.

For multi-storey applications, fire stops are required at each floor level. If an offset is needed, additional pipe, elbows and supports will be required.

Do not exceed the maximum number of elbows. One 90° for horizontal terminations and two 45° for vertical termination.

Dura-Vent Vertical Termination Installation

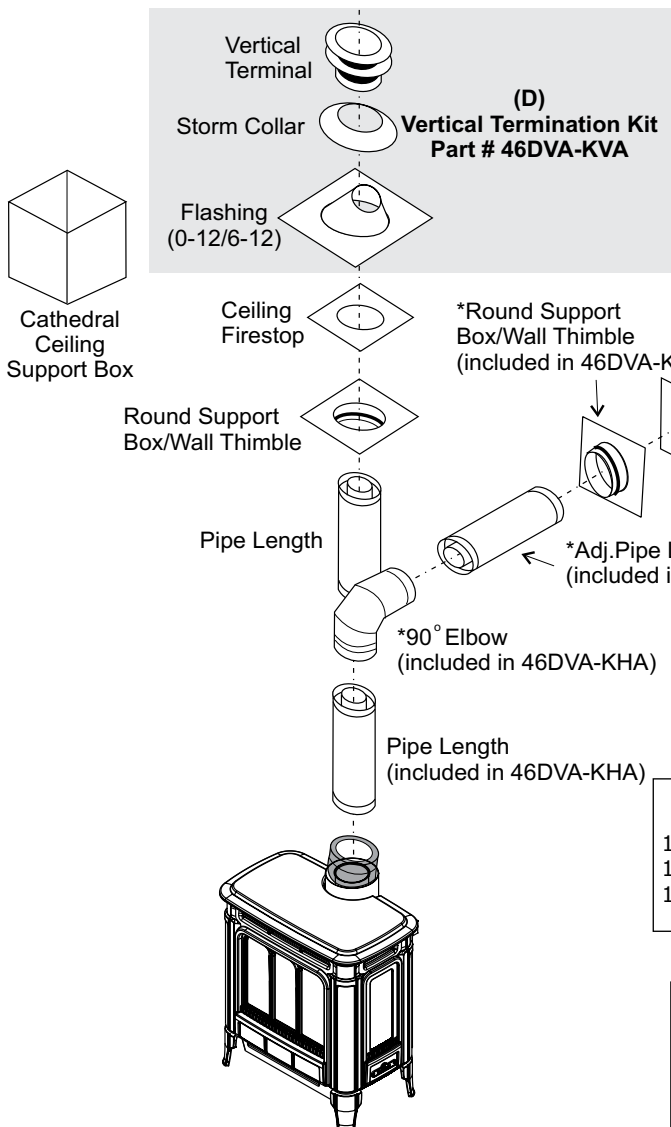

Dura-Vent Horizontal Termination Installation

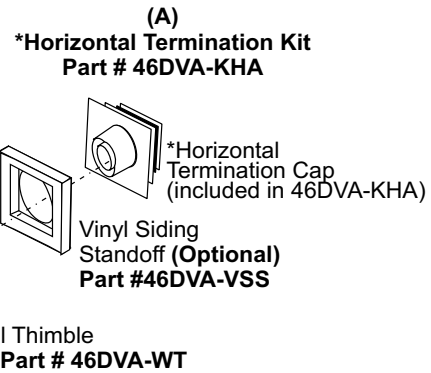

Alternate Horizontal Termination Caps AstroCap Part# 946-523/P

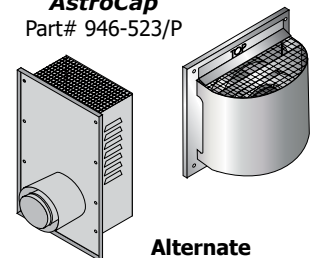

Alternate Horizontal Riser Vent Terminal Part# 640-530/P

- Basic Horizontal Kit**
- 1 90° Elbow
 - 1 Wall Thimble Cover
 - 1 Horiz. Sq. Term. Cap

The FPI AstroCap™ is certified for installations using FPI venting systems as well as Simpson Dura-Vent® and Direct Vent Pro. The FPI AstroCap™ is the proprietary trademark of FPI Fireplace Products International Ltd. Dura-Vent® and Direct Vent Pro are registered and/or proprietary trademarks of Simpson Dura-Vent Co. Inc.